



## MODIFICATION OF WCS-300B TO PROVIDE CHANNEL SELECTABLE PTT

### 1. EFFECTIVITY

This service bulletin may be accomplished at customer request on the WCS-300B. The modification may be accomplished upon receipt of this bulletin.

### 2. BACKGROUND

This service bulletin allows a modification to the WCS-300B to provide PTT (push to talk) capability on one or more channels and will disable PTT on the remaining channels.

### 3. DESCRIPTION

The intent of Service Bulletin WCS-300B-3 is incorporated in the WCS-300B by routing the PTT line through the unused rear deck of the channel select rotary switch per the Accomplishment Instructions.

Label GWS PN 156-0100-000 must be placed on the back of the unit and marked Mod 5 to indicate incorporation of Service Bulletin WCS-300B-3.

### 4. MANPOWER

This modification takes approximately 1/2 man hour.

### 5. APPROVAL

Meets all requirements of applicable specifications.

### 6. MATERIALS

Mod Label, GWS PN 156-0100-000

Heat-Shrink Tubing

Wire

(use appropriate heat-shrink tubing and wire as necessary)



## 7. ACCOMPLISHMENT INSTRUCTIONS

- A. Remove cover from transceiver per maintenance instructions in Global Wulfsberg Systems' Maintenance Manual PN 150-0113-000.
- B. Locate the A9J3-3 connector. See Maintenance Manual PN 150-0113-000 for component locations.
- C. Remove the heat shrink tubing from A9J3-3.
- D. Unsolder the three wires connected to A9J3-3. See Maintenance Manual PN 150-0113-000 for wiring interconnect.
- E. Separate the 2 wires running to A9P1-D and E from the third wire. The use of the third wire is described in Step H.
- F. Connect the wires from A9P1-D, E to the switch terminals on the rear deck of A9S1 corresponding to the channel(s) that will have the PTT capability. See Figure 1. For example, if PTT is desired on channel 1 only, connect the wires to terminal 1.
- G. Connect a new wire to the rear deck common terminal on A9S1 offset from the switch terminals. See Figure 1.
- H. Connect the opposite end of the new wire to the remaining wire removed from A9J3-3 in Step D. See Figure 1.
- I. Slide on a new piece of heat-shrink tubing.
- J. Solder the wires to A9J3-3.
- K. Heat tubing to shrink into place.
- L. Replace WCS-300B cover and screws per maintenance instructions.
- M. Place Label GWS PN 156-0100-000 on back of unit and mark Mod 5.

## 8. WARRANTY PROVISIONS

Global Wulfsberg does not reimburse for labor charges incurred while incorporating Service Bulletin WCS-300B-3.

## 9. COST AND AVAILABILITY

For cost and availability information, contact Sales Administration, Irvine, CA, (714) 851-0119.



# SERVICE BULLETIN

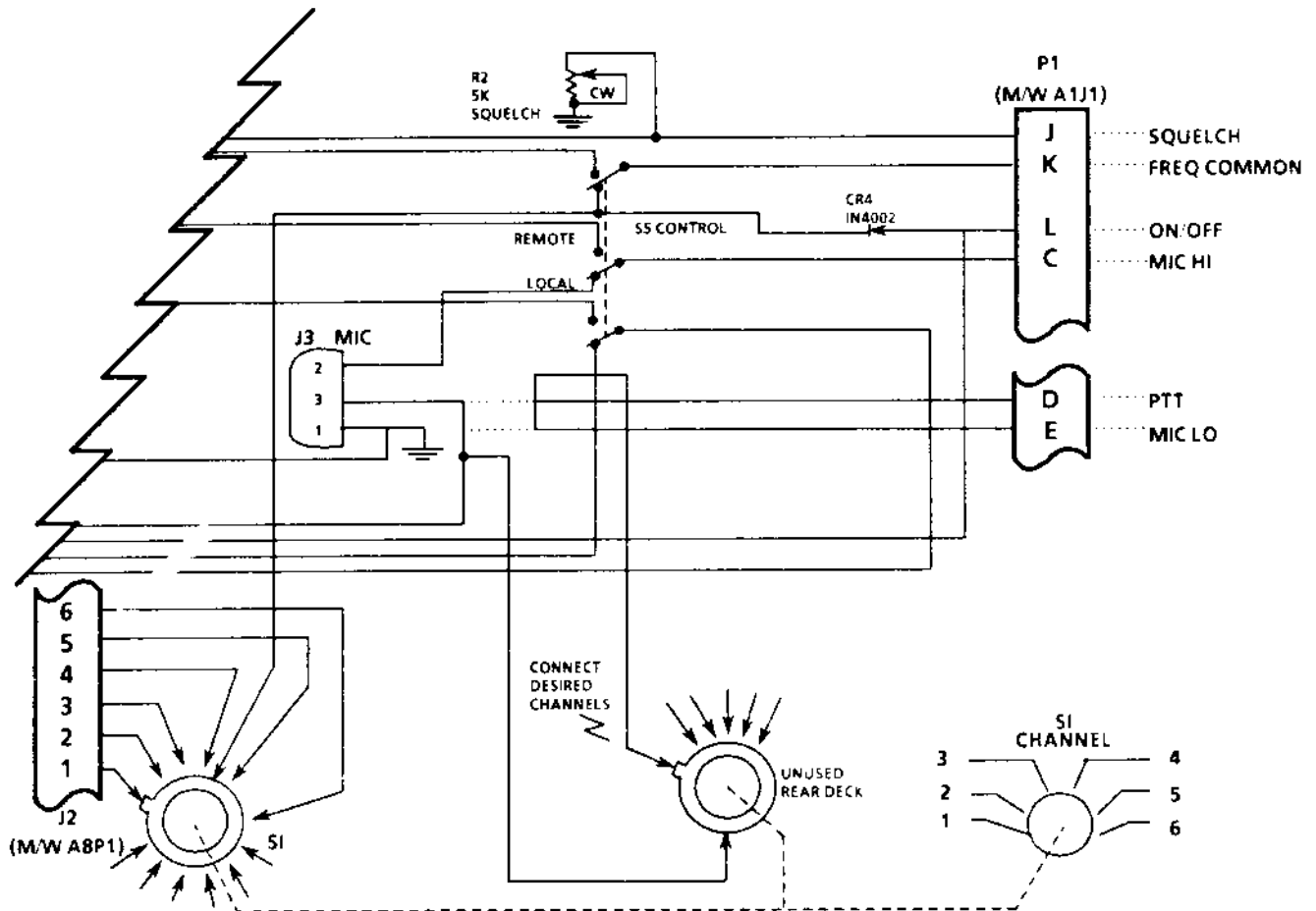

Revised WCS-300B Chassis (A9) Schematic  
 Figure 1

