

Service bulletin Nr. 1
Dated Feb. 2, 1999SHEET
1 OF 3Equip. RGT-102
P/N 907-1102-XXX

The purpose of this modification is to improve operation of the control panel during abnormally low DC input bus voltage.

1.0 Planning information

- 1.1 Applicable to all control panels with P/N 907-1102-XXX.
- 1.2 Applicable to all serial numbers.
- 1.3 Modification involves the replacement of two resistors.
- 1.4 Conforms to EMH Tech's configuration control procedures.
- 1.5 Estimated time to complete the modification and to re-test the control panel is .7 manhours.

2.0 Modification procedure

- 2.1 Remove 4 bottom cover retaining screws and lift the cover Free. Save the cover and the screws.
- 2.2 Identify resistors R111 and R113 on the A1 assembly..
- 2.3 Remove resistors R111 (1 megohm) and R113 (2000 ohms) Discard both resistors.
- 2.4 Clean solder from R111 and R113 mounting pads.
- 2.5 Install new value resistors R111 (82K ohm) and R113 (180 ohm)
- 2.6 Clean any solder flux and residue from affected area.
- 2.7 Coat cleaned area with a light coating of urethane.
- 2.8 Install bottom cover and 4 retaining screws.

Service bulletin Nr. 1

SHEET

Equip. RGT-102Dated Feb. 2, 19992 OF 3P/N 907-1102-XXX

2.9 Re-test the unit in accordance with EMH Tech's RGT-102
Test procedures.

2.10 Identify the MOD status by painting over the 1 on the unit
Nameplate with yellow paint. The nameplate is located on a
Side rail of the control panel.

2.11 Sign off and attach the appropriate paper work.

Service bulletin Nr. 1
Dated Feb. 2, 1999

SHEET:
3 OF 3

Equip. RGT-102
P/N 907-1102-XXX

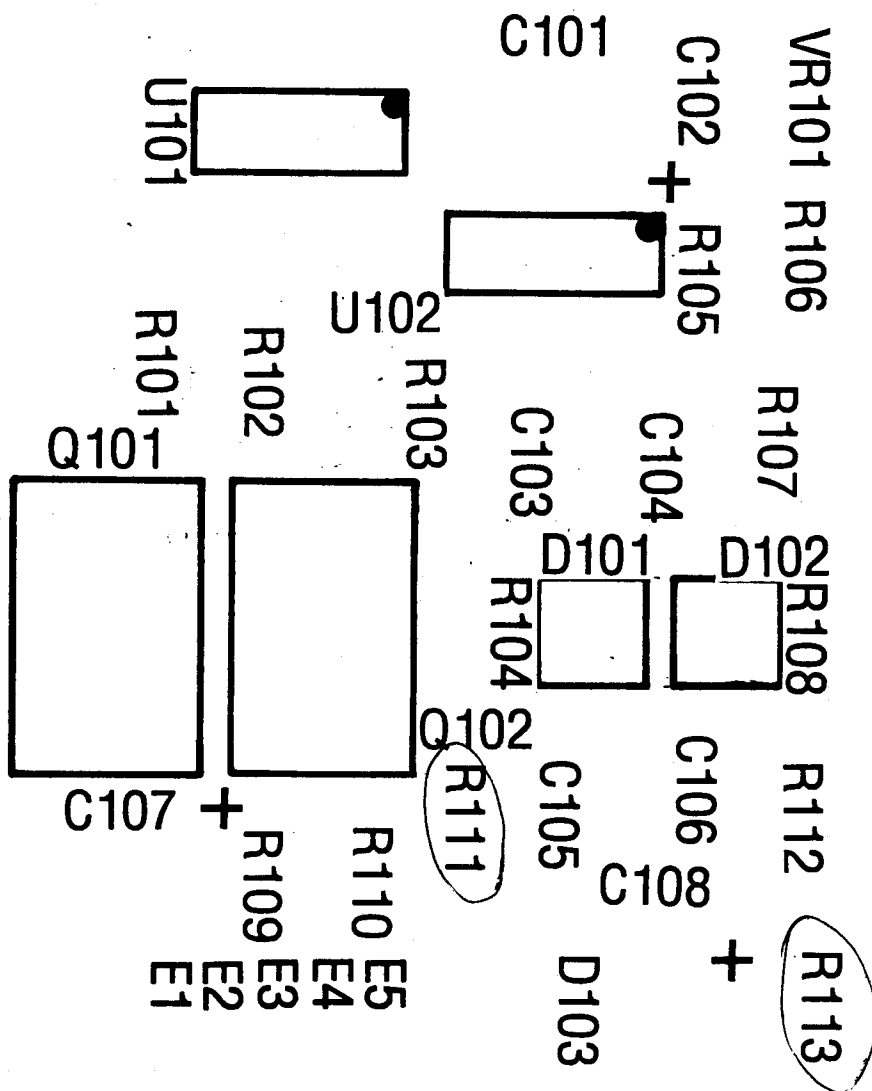

A1 ASSEMBLY